

# Technical Drawings: Methods to Display Shape and Size

Creating technical drawings involves using particular tools and techniques. For example, when creating a freehand sketch of an object, it's important to always use grid paper. This will help you make sure that your scale is correct. A medium-weight lead or drawing pencil with a rounded point works best for making freehand sketches.

These are the basic tools for technical drawing:

- A T-square, used for drawing horizontal lines
- Triangles (both a  $45^\circ$  and a  $30/60^\circ$ ), used to draw vertical and angled lines when placed on the T-square
- A protractor, used to measure angles
- A ruler, used to make proportional drawings at greater or reduced sizes
- A compass, used for drawing arcs and circles

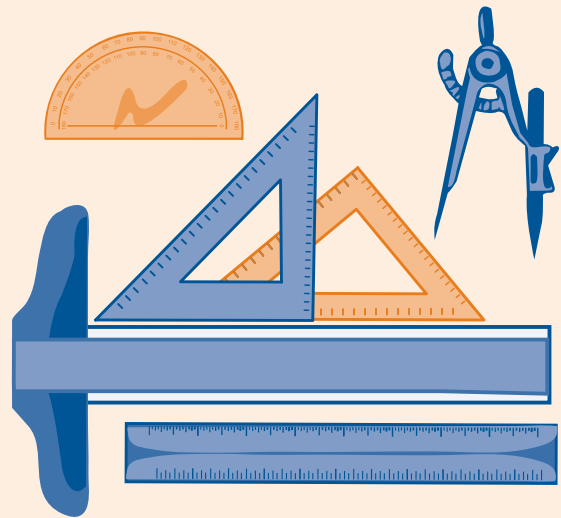

## Isometric Drawings—Giving a Three-Dimensional View

An isometric drawing shows many sides of the same object; the top, front, and side views are equally visible. The purpose of an isometric drawing is to give people a realistic view of the object. The following figure shows the angles used to draw an isometric figure:

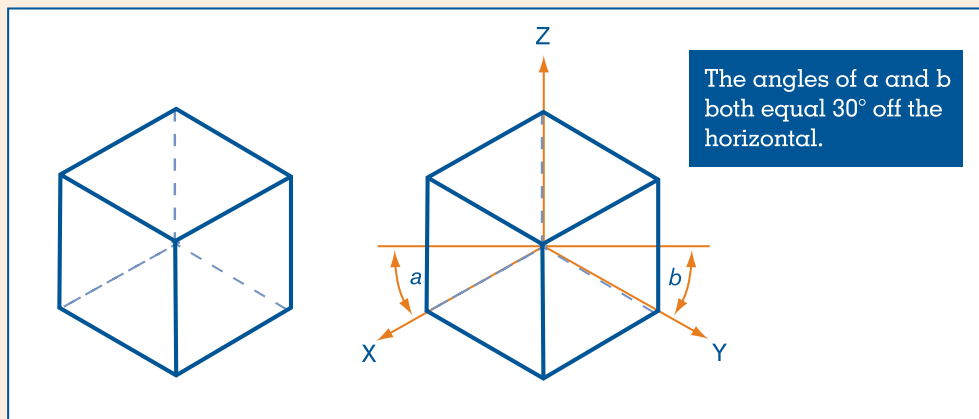

Isometric grid paper makes it easier to figure out the angles and draw an object in 3-D. **Figure 5.1** is an isometric drawing of Widget XYZ on isometric grid paper.

**Figure 5.1: Widget XYZ on Isometric Grid Paper**

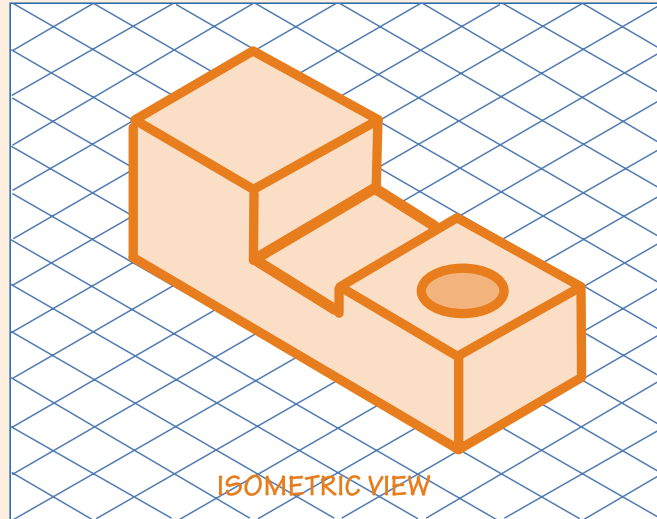

### Orthographic Drawings—Showing the Shape of an Object

**Orthographic drawings** present usually three, but as many as six, different views of an object, all at right angles to one another.

**Figure 5.2** is an example of an orthographic drawing. Notice that the angle between the top, front, and side views of the object is 90 degrees (a right angle)—just like the actual sides of the widget.

**Figure 5.2: Widget XYZ**

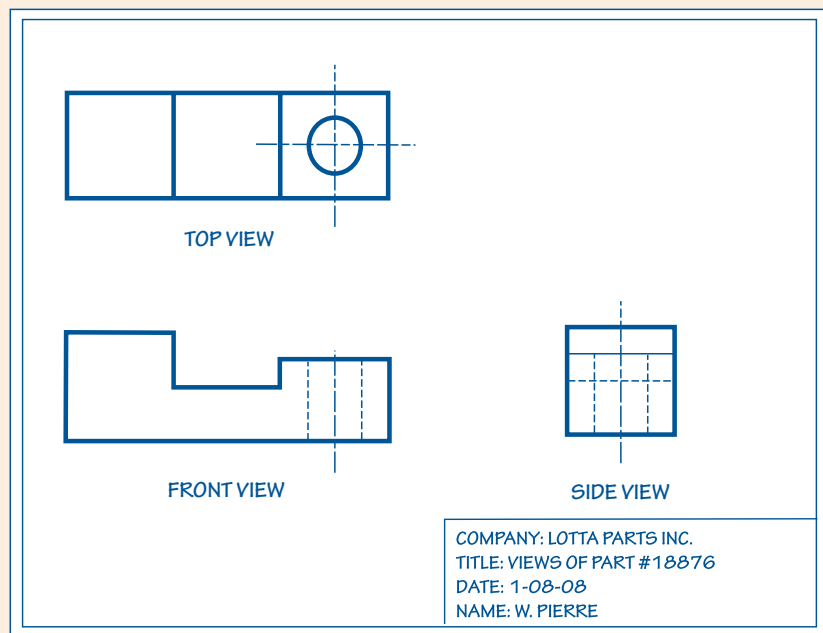

Imagine drawing a child’s wooden block. Look at it from the top—this is the block’s “top view.” Looking at the front face of the block gives you its “front view.” Turning the block to the right gives you its “side view.”

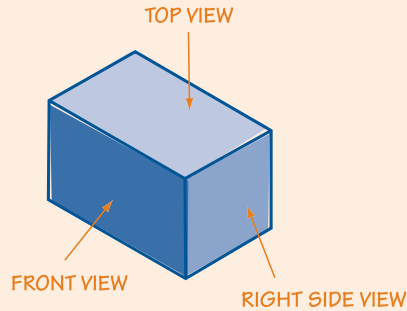

When making an orthographic drawing, remember the following general guidelines:

1. Position the top view above the front view so that the lengths of each view line up.
2. Position the right side view to the right of the front view so that the heights line up.

### Dimensions—Showing the Size of an Object

Illustrations or sketches often show an idealized view of an object. While illustrations are effective tools for showing the general look of an object, a technical drawing needs to give enough information to convey its actual shape and dimensions. Figure 5.3 shows how the dimensions of a birdhouse are conveyed in the multiple views shown in a technical drawing.

**Figure 5.3: Orthographic Drawing of a Birdhouse**

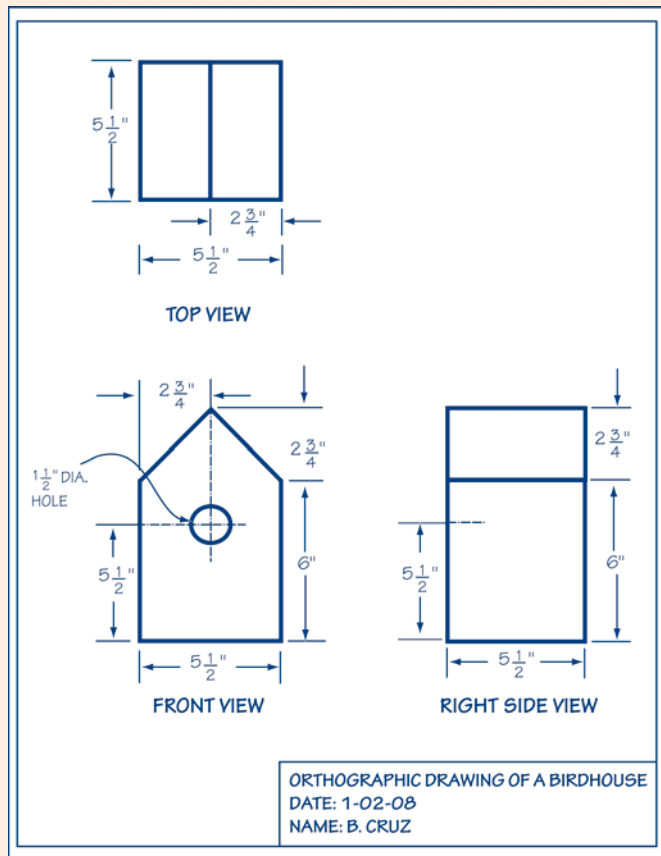

## Guidelines for Drawing an Object

Use the following guidelines to construct a basic orthographic drawing with **dimension lines** (lines to display the length of the side of an object or the locations of particular features, such as holes and notches; these lines run parallel to the object, include arrows at both ends, and have a blank space in the middle for the numerical value of the length):

1. Study the object and determine the views (front, back, top, left side, or right side) that will be needed to completely describe the object. If any sides are identical, you may not need to repeat those views.
2. Determine a scale that matches your paper. Most grid paper displays a  $\frac{1}{4}$  or  $\frac{1}{8}$ -inch grid. Measure your object (if you are drawing a real object) and choose the actual length that will correspond to  $\frac{1}{4}$  or  $\frac{1}{8}$  inch on your paper. For example, a 1-inch measurement of the actual object may be represented by  $\frac{1}{4}$  inch on your graph paper. Also, be sure to choose a scale that makes efficient use of your paper—fill the page and show the object clearly. You don't want to choose a scale so small that your drawing only uses a tiny portion of the page!
3. Using a ruler and any other technical drawing tools you have available, draw each view on your grid paper.
4. For each view, include dimension lines to display the length of the side or the location of particular features, such as holes and notches. Dimension lines showing specific features should be drawn first, closest to the object, with dimension lines showing the total length of the sides outside the feature dimension lines. **Figure 5.4** provides an example.
5. Indicate the ends of dimension lines with extension lines—short solid lines drawn outward from the side of an object. These lines should not touch the views to which they refer, unless they connect to a center line. Orient your dimension numbers horizontally so they can be read without rotating the page.
6. Include leader lines if necessary to indicate details about specific features of the object, such as a hole. Leaders are freehand lines with at least one wave or curve and an arrowhead.
7. Technical drawings have standard sizes of 8.5" x 11", 11" x 17", 17" x 22", 22" x 34", and 34" x 44" (all multiples of 8.5 x 11). A border line should be drawn  $\frac{1}{2}$  inch from the paper's edge around the drawing.
8. Include a title block listing the name and a description of the drawing, the name of the person who drew it, the scale, and the date.

Figure 5.4: Border, Center, Dimension, Extension, and Leader Lines

